

## Tangential fan application

Tangential fans are generally supplied as a complete package of impeller, housing and motor. However, the impeller and motor could be obtained separately and the necessary scroll and vortex tongue can be incorporated in the application.

The tangential fan is similar to that of a forward curved centrifugal in that the power input reduces as more pressure is developed. The efficiency characteristic is not the same as a forward curved centrifugal. The tangential fan provides relatively low volume and low pressure and peak efficiency is achieved at about two thirds volume flow. The best operation area is from this point down to free air.

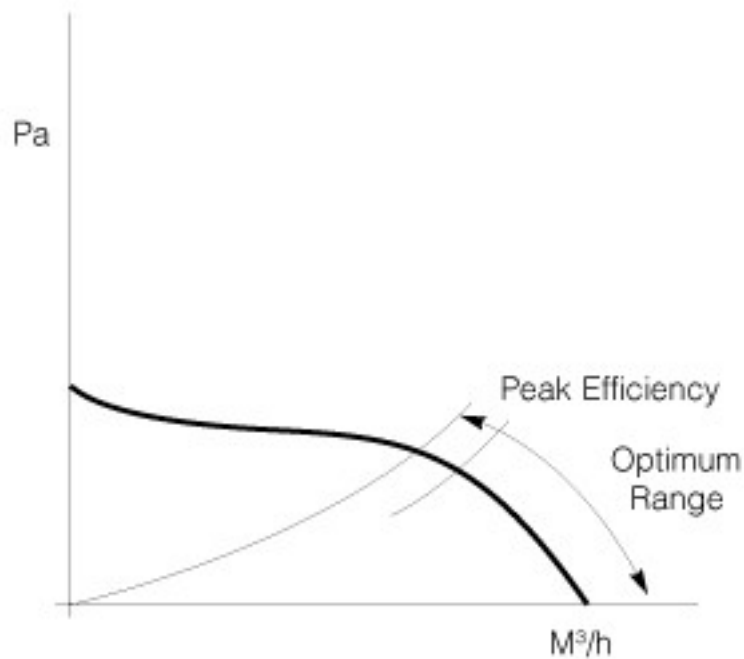

*Typical tangential fan curve*

## Key components

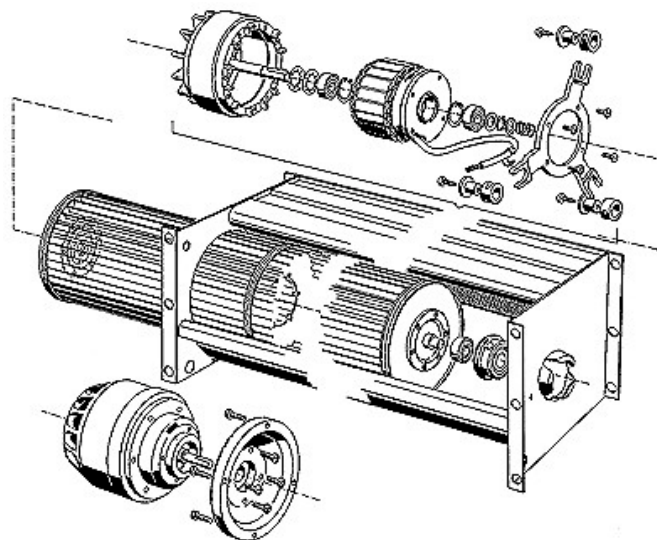

*Exploded view of a tangential fan*

A tangential impeller cannot be used without a housing or vortex tongue. Like an axial fan, the impeller is sensitive to the turbulent air entering the intake side. It is recommended to keep obstructions on the inlet side at a minimum distance from the intake.

### Resistance bodies

Rods, bracings, bearing plates and the like do not only obstruct the flow but cause annoying noise. For this reason, these should not be arranged too close to the impeller. It is advisable to keep a minimum distance of 4 times the diameter of the source of interference to the rotating vanes.

